

# FMT-301(NL) OPERATING MANUAL

## 27MHz REMOTE CONTROL DIGITAL TRANSMITTER

The FMT-301(NL) is an updated model of the FMT-201(NL). The FMT-301(NL) has an improved transmission, which complies with American, Canadian and European radio frequency regulations. The FMT-301(NL) is part of a single channel remote control system. A few of its applications could be as:

- a remote control switching device for garage doors, lights, gates, and automatic telephone dialer.
- a personal security alarm activator for home safety or cash carrying businesses e.g. banks, shops service stations, etc.
- a calling device for the elderly or handicapped.

The transmitter is housed in an attractive, high impact resistant grey ABS plastic case.

Pressing the designated switch on the front positively activates the transmitter. Activation is confirmed by the sound of its built-in buzzer.



The highest possible standard of performance is achieved by employing a crystal-controlled, frequency modulated radio signal operating in the 27MHz band. This is enhanced by a specially dedicated custom-built integrated circuit. The latest "state of the art" surface-mount technology (SMD) provides maximum reliability.

A 12-way code switch (part of the digital encoding system) is used in place of the usual 8 or 10 way systems of other manufactures. This enables the user to select any one of the 4096 available codes and thus ensure highest security against false operations. The code can be readily changed at any time.

An operating distance (in conjunction with our FMR series receivers) of 500 metres is possible.

The operating distance depends upon the receiver antenna and location. An independent test revealed the following ranges:

<b>Range (Metres)</b>	<b>Receiver Antenna</b>	<b>Receiver Type</b>
100	250 mm Long Wire	FMR-...
400	1000 mm Long Wire	FMR-...
>500	ANT27M	FMR-...

Range tests were done in an open area test site with line-of-sight operation and the receiver antenna wire was fixed vertically, away from any metal objects.

When operating near its range limit, some improvements may be obtained by pointing the transmitter towards the receiver. This is due to its slightly directional properties.

The case of the transmitter has been designed to accept Elsema's leather covers. The leather covers have a belt clip.

The transmitter is also available without its front label (No Label, FMT-301NL). This enables the fitting of customer's own labels.

## DIMENSIONS FOR CUSTOMISED FMT-301 LABEL

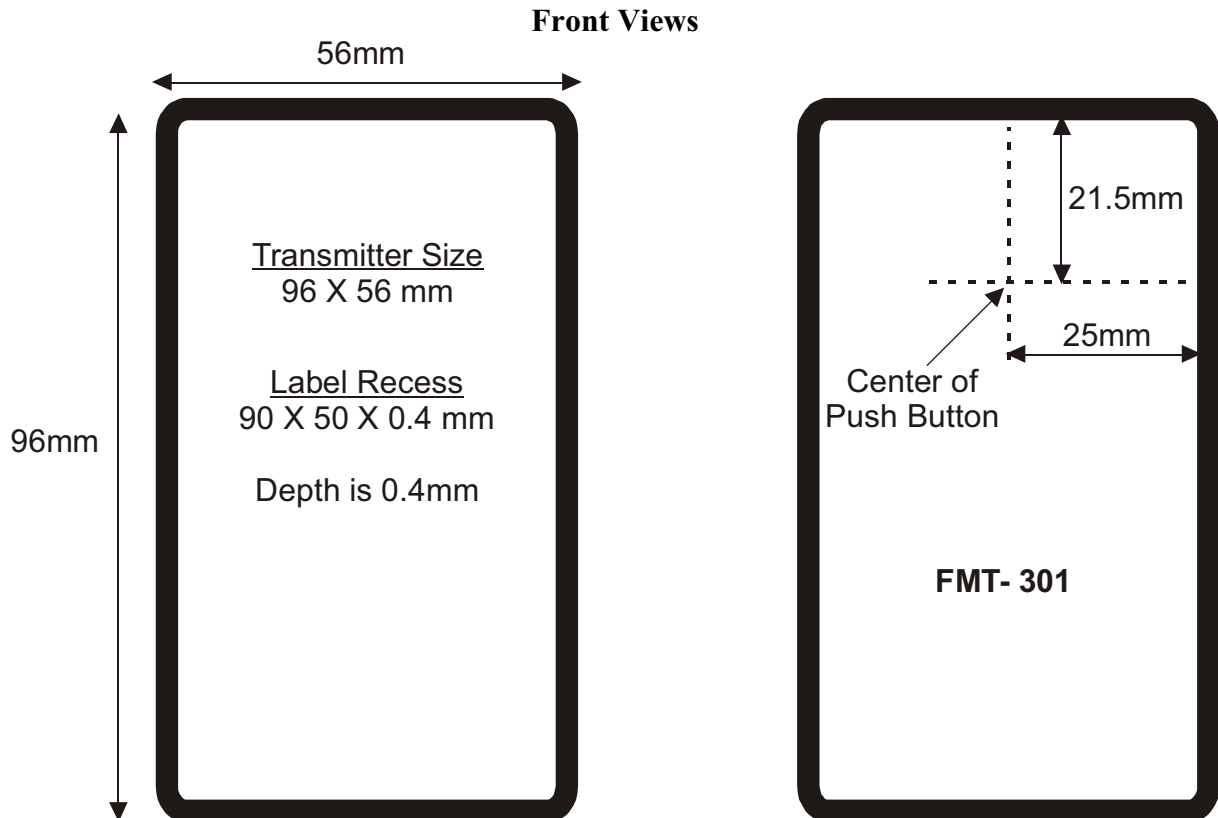

### Notes:

- Label size should be 0.5 mm less than the above recess i.e. 89.50 X 49.50 mm.
  - Rounding in the corners is 4.3 mm (11/64") diameter.
  - On the four-channel transmitter, channel –one is at the extreme left followed by channel-two, etc
- Recommended label material : Polyester Autotex F200

### Label Suppliers :

Entech Integrated Manufacturing  
Australia  
Phone : (61) 8 8373 6116  
Fax : (61) 8 8373 6018

Screen Printing  
Australia  
Phone : (61) 2 9676 4560  
Fax : (61) 2 9676 4561

Permark Industries Aust (1999) Pty Ltd  
Phone : (61) 2 9911 6656  
Fax : (61) 2 9819 6517  
Email : [amrat@permark.com.au](mailto:amrat@permark.com.au)

## REGULATORY COMPLIANCE STATEMENTS

### **American Users**

This device complies with Part 15 of the FCC Rules. Operation is subject to the following two conditions:

- (1) This device may not cause harmful interference and
- (2) This device must accept any interference received, including interference that may cause undesired operation.

### FCC Notice

This device has been tested and found to comply with the limits for a Class B digital device, pursuant to Part 15 of the FCC Rules. These limits are designed to provide reasonable protection against harmful interference in a residential installation. This device generates, uses, and can radiate radio frequency energy and, if installed and used in accordance with the instruction, may cause harmful interference to radio communications. However, there is no guarantee that interference will not occur in a particular installation. If this device does cause harmful interference to radio or television reception, the user is encouraged to try to correct the interference by one or more of the following measures:

- Reorient or relocate the receiving antenna.
- Increase the separation between the computer and receiver.
- Connect the computer into an outlet on a circuit different from that to which the receiver is connected.
- Consult the dealer or an experienced radio/TV technician for help.

Caution: Any changes or modifications not expressly approved by the grantee of this device could void the user's authority to operate the equipment.

### **Canadian Users**

This Class [B] digital apparatus meets all requirements of the Canadian Interference-Causing Equipment Regulations.

Cet appareil numérique de la classe [B] respecte toutes les exigences du Règlement sur le matériel brouilleur du Canada.

### **European Users**

This information Technology Equipment has been tested and found to comply with the following European directives:

- ETS 300 683
- I-ETS 300 220

### **Australian and New Zealand Users**

This device has been tested and found to comply with the limits for a Class [B] digital device, pursuant to the Australian/New Zealand standard AS 4268.2 (1995) set out by the Spectrum Management Agency.

## TECHNICAL DATA ON FMT-301(NL)

POWER SOURCE :	9-Volt Battery Carbon : approximately 1-year shelf life (6F22) Alkaline: approximately 2-year shelf life
SUPPLY VOLTAGE :	6 to 16 VDC (For constant RF-Output)
CURRENT CONSUMPTION :	40mA (Typical) at 8VDC supply while transmitting
OPERATING FREQUENCY:	27.145MHz (Other frequencies available on 27.045, 27.195 and 27.455 MHz. The 27.455 frequency is not available for Australia).
CARRIER FREQUENCY TOLERANCE :	Crystal controlled 30 parts per million (0 to 50° C)
RADIATED FIELD STRENGTH:	70 dB $\mu$ V/m at 3 metres (+-3dB) or 3 $\mu$ Watts
ANTENNA :	Built in 50mm proprietary DILEC rod
TYPE OF EMISSION:	Narrow-band-width Frequency Modulation (5K00F1D)
FREQUENCY DEVIATION :	1600 Hz non-return to zero (+-20%)
TYPE OF MODULATION :	Manchester format 1.08 ms per bit (15% tolerance)
BITS PER SECOND	926 bps
SPURIOUS TRANSMISSION :	Complies with FCC 15.227 (USA), MPT 1346 pt 4.5 (UK) and ETS 300 220 (Europe)
NECESSARY BAND WIDTH :	+ - 5.0 KHz
DIGITAL CODING SYSTEM :	On board 12-way coding switch (4096 codes)
DIMENSION :	96 X 55 X 20 mm
WEIGHT :	70g excluding battery
USEABLE OPERATING RANGE :	500 metres. Depends on receiver antenna and location
COMPATIBLE RECEIVERS :	All Elsema type FMR-... series

Due to its popularity, ELSEMA PTY. LTD stocks the Carbon Battery 6F22. The indicated shelf life is only approximated and can vary greatly depending on the freshness and type of brand used.

# FMT-301(NL) BLOCK DIAGRAM

